

SERIES 216.40

SELF-PRIMING HORIZONTAL SCREW PUMP FOR NON LUBRICATING LIQUIDS

PRODUCTS

WATER

SEAWATER

OILS

HEAVY FUEL OILS

LIGHT PRODUCTS

LABELLING

BILGE/BALLAST PUMPS

GENERAL SERVICE PUMPS

CARGO PUMPS

TRANSFER PUMPS



A COLFAX BUSINESS UNIT



HOUTTUIN B.V.



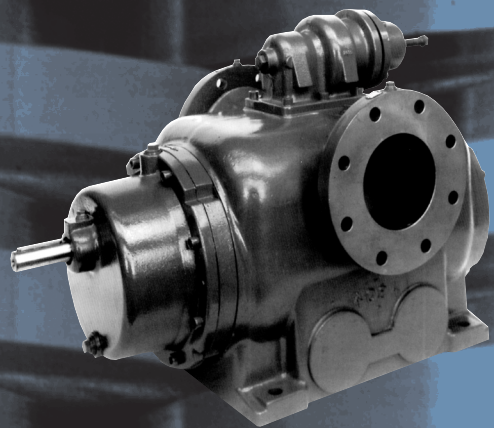

Principle

The Houttuin double entry twin screw pumps series 216 are horizontal rotating self priming positive displacement pumps.

Two inter-meshing screws rotating in a pump casing insert ensure high pumping efficiency with constant axial flow and unequalled suction power.

Construction

The spindles are supported and axially held in position by ball bearings. The transmission of torque from the driven spindle to the idler spindle is effected by oil lubricated timing gears located outside of the pumping area in an attached gearbox. The ball bearings and timing gears maintain a small clearance between the screws, thus preventing metal to metal contact.

Shaft sealing

Single unbalanced mechanical seals keeping the liquid to be pumped isolated from the bearings and the gearbox.

Overload protection

For protection against overload a built-on spring loaded relief valve can be supplied.

Applications

For pumping contaminated or slightly abrasive, lubricating and non-lubricating liquids of low or high viscosity which do not chemically attack the pump materials (corrosion proof materials can be offered). In the chemical and petrochemical industry, soap and grease industry, paint and lacquer industry, food and beverage industry, plastics industry, sugar industry, environmental technology, in tank farms and in the shipbuilding industry.

Products

- Water
- Seawater
- Oils
- Heavy fuel oils
- Light products

Labelling

- Bilge/ballast pumps
- General service pumps
- Cargo pumps
- Transfer pumps

Performance data

Capacity	Q	up to 1100 m ³ /h
Viscosity range	V	0,6 to 1500 cSt
Temperature of pumped liquid	t	up to 100 °C
Inlet pressure	p _s	up to 10 bar
Outlet pressure	p _d	up to 16 bar
Difference pressure	Δp	up to 16 bar
Speed	n	up to 2900 rpm
Flanges		according to DI or ANSI

A preliminary pump selection can be effected by means of the performance graphs. For the exact performance data as function of the viscosity of the liquid to be pumped and the pump speed, please refer to the individual characteristics.

AVAILABLE MATERIALS

FOR PUMP AND MECHANICAL SEALS:

Pump				Mechanical seal according to DIN 24960 / API		
Screw shafts	Casing insert	Casing	Covers	Seal faces	Springs	'O' -rings
- Carbon Steel	- Cast Iron	- Cast Iron	- Cast Iron	- Chrome Steel or	- Stainless	- Viton
- Stainless Steel (Type 400)	- Nodular Cast Iron	- Nodular Cast Iron	- Cast Iron with coating	- Silicon Carbide against	Steel (Type 300)	- Teflon
- Stainless Steel (Type 300)	- Ni-Resist	- Ni-Resist	- Nodular	- Carbon		
	- Bronze	- Cast Iron with coating	- Carbon Steel			
		- Bronze	- Stainless Steel			
		- Carbon Steel				
		- Stainless Steel				

Flow rate/pressure at minimum and maximum viscosity according to pump size.
 For exact performance data dependant of viscosity and rpm please refer to the individual characteristics per pump size.

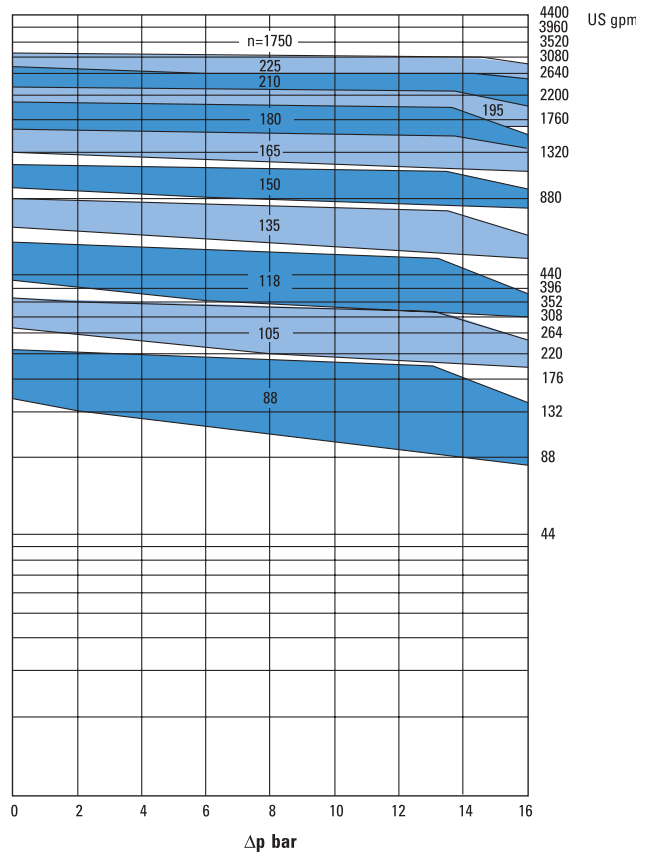
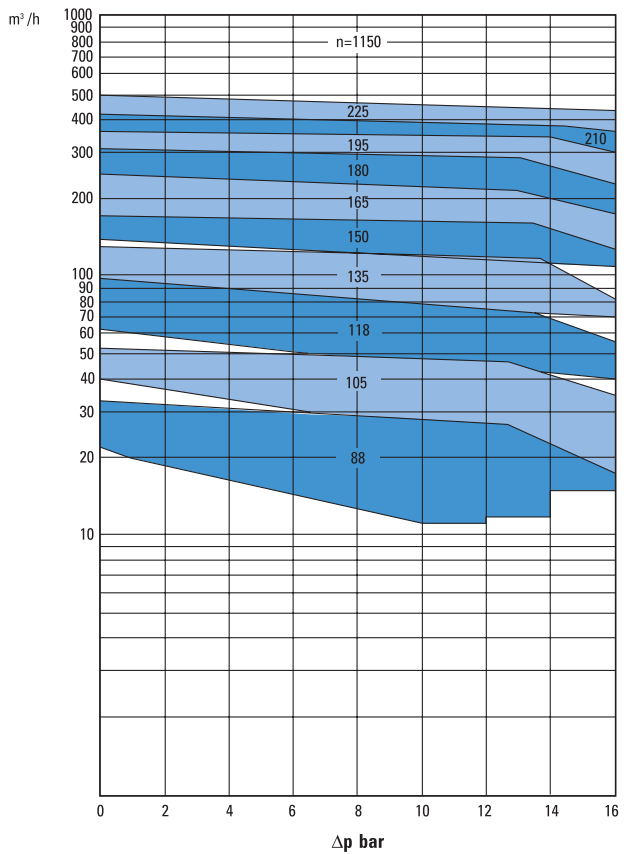
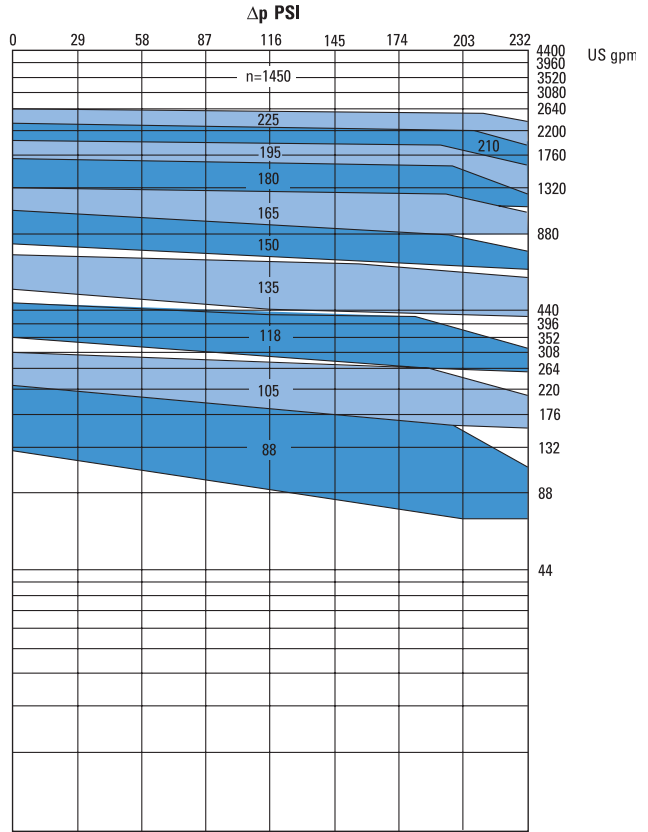
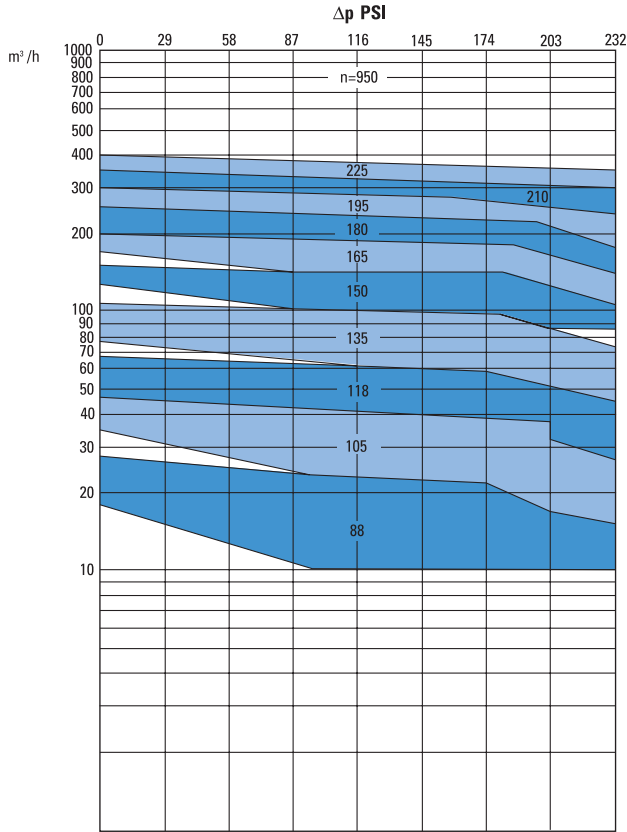

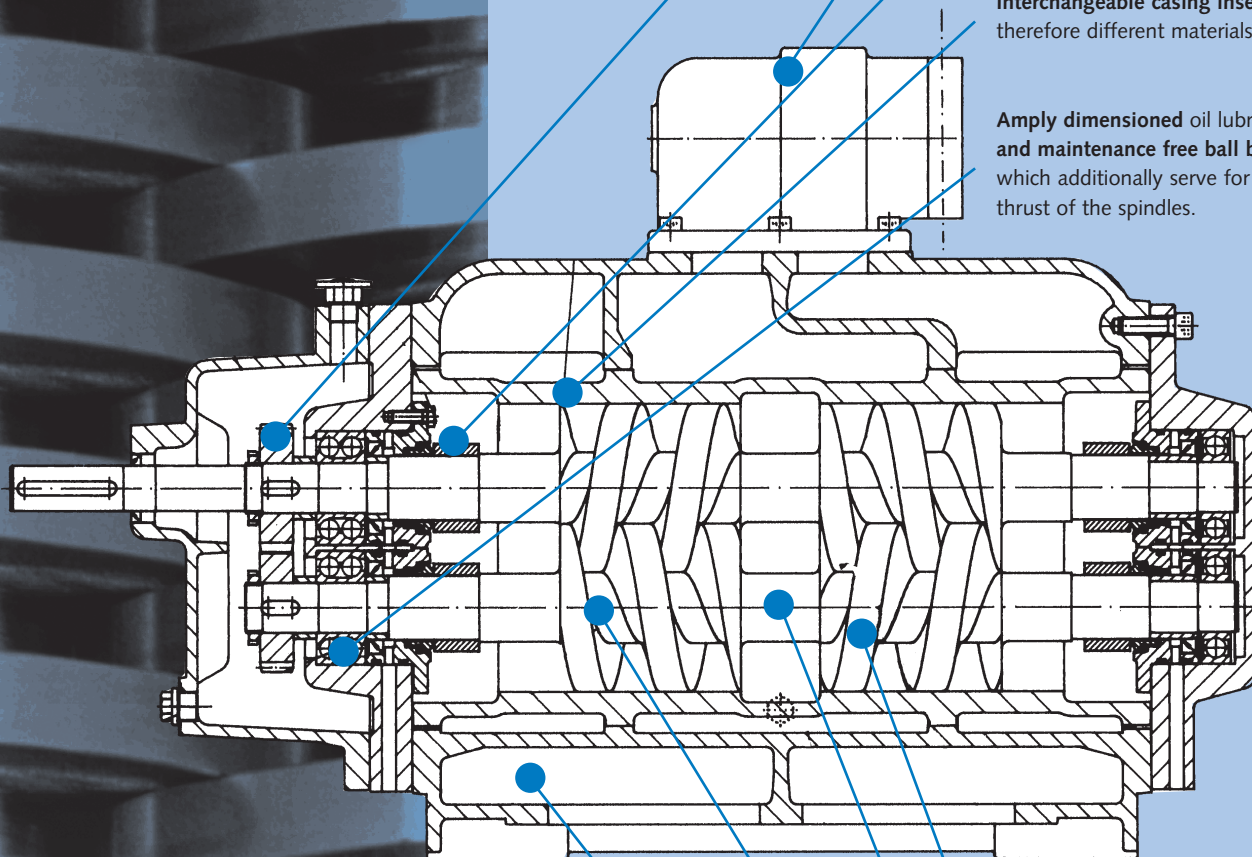

Safe transmission of torque through hardened and ground oil-lubricated timing gears.

For **overload protection** a direct mounted pressure relief valve is optional.

Safe shaft sealing by single unbalanced and product lubricated mechanical seals.

Interchangeable casing insert therefore different materials possible.

Amplly dimensioned oil lubricated and maintenance free ball bearings, which additionally serve for the axial thrust of the spindles.



ONLY SIZE 088

The special profile of the spindle flanks results in **continuously and nearly pulsation-free pumping**, high efficiency, good NPSH-values and constant pressure course.

Axial forces balanced through double entry spindles.

Rigid spindles of solid material therefore compared with multi-part spindles **no crevice corrosion**.

Heating of the pump foot is optional.

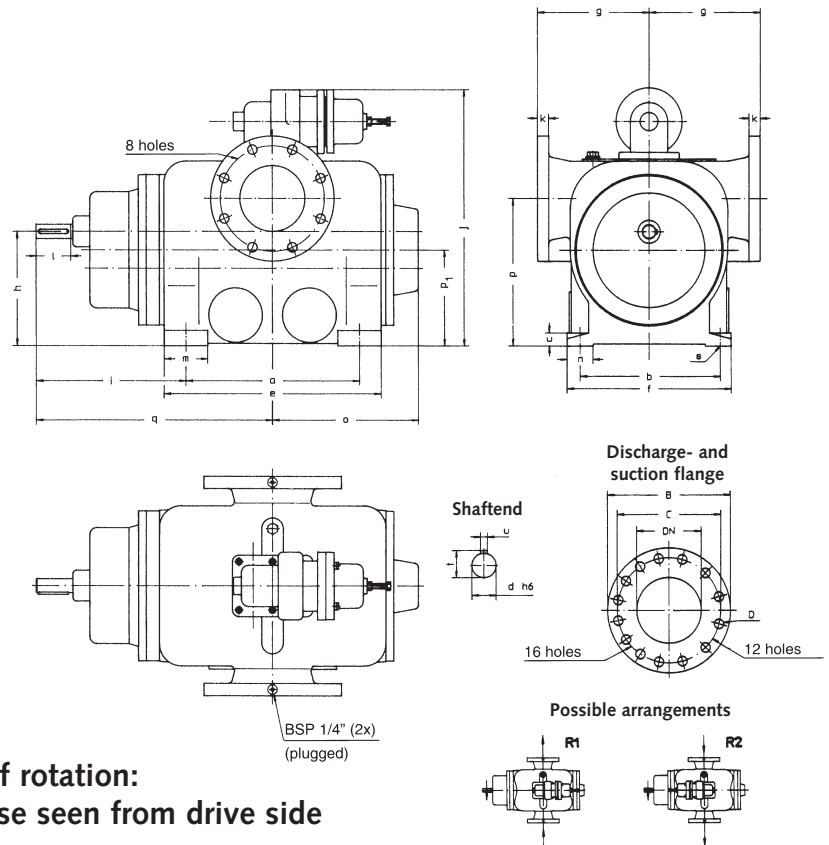

Sense of rotation:
clockwise seen from drive side

PUMP SIZE	PUMP DIMENSIONS								FLANGES PN 16 DIN 2533				RELIEF VALVE SIZE
	a	b	c	e	f	m	n	s	DN	B	C	D	
088	325	310	35	415	350	90	60	4x18	100	228	180	8x18	46
105	370	330	35	460	370	90	60	4x18	125	254	210	8x18	46
118	400	335	35	500	380	100	60	4x22	150	285	240	8x22	70
135	480	400	40	570	450	100	70	4x22	200	340	295	12x22	70
150	580	450	40	670	500	100	70	4x22	250	405	355	12x26	100
165	620	490	45	740	550	120	90	4x26	250	405	355	12x26	100
180	670	540	45	790	600	120	90	4x26	300	460	410	12x26	100
195	680	590	45	800	650	120	90	4x26	300	460	410	12x26	135
210	690	600	45	840	660	150	120	4x26	300	460	410	12x26	135
225	700	660	45	850	720	150	120	4x26	350	520	470	16x26	135

PUMP SIZE	PUMP DIMENSIONS								SHAFT END					WEIGHT KG (CA)
	g	h	i	j	k	o	p	p1	q	d	l	t	u	
088	230	230	292,5	478	26	287	305	197,5	455	28	60	31	8	150
105	240	245	300	496	26	312	310	207,5	485	28	60	31	8	200
118	250	260	345	590	26	335	335	218	545	32	80	35	10	250
135	275	280	341	635	30	373	355	233	581	38	80	41	10	350
150	300	305	387	785	32	430	400	252,5	677	42	110	45	12	500
165	320	335	426	812	32	477	425	277,5	736	45	110	48,5	14	720
180	350	355	440	877	32	505	465	292	775	50	110	53,5	14	950
195	370	375	460	927	32	513	480	307	800	55	110	59	16	1050
210	390	395	525	979	32	535	520	321,5	870	60	140	64	18	1250
225	435	415	540	1025	36	545	540	336,5	890	65	140	69	18	1400

dimensions in mm, dimensions are subject to alternations.

*) The diagrams show the performance range of the different pump series in our pump program and are for information only.

STANDARD PUMPS

With Internal Bearings

for lubricating liquids

viscosity range : 20 - 760 cSt
: 98 - 3500 SSU

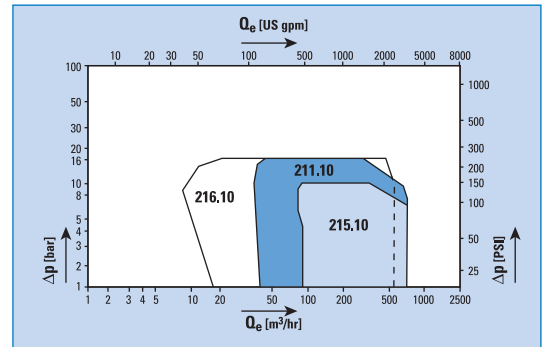

With External Bearings

for non-lubricating liquids

viscosity range : 0,6 - 1500 cSt
: 32 - 7000 SSU

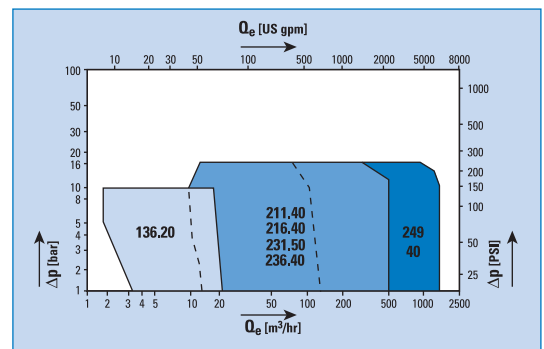

With External Bearings

for lubricating and non-lubricating liquids

viscosity range : 0,6 - 100.000 cSt
: 32 - 466.000 SSU

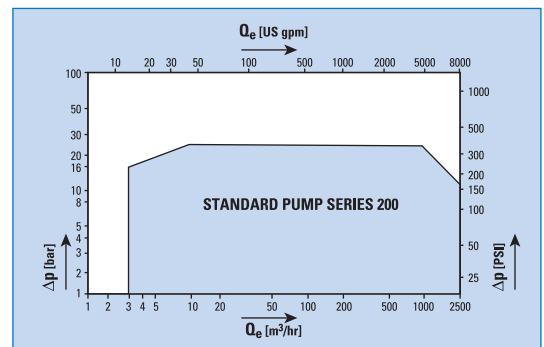

ENGINEERED PUMPS

With External Bearings

for lubricating and non-lubricating liquids

viscosity range : 0,6 - 100.000 cSt
: 32 - 466.000 SSU

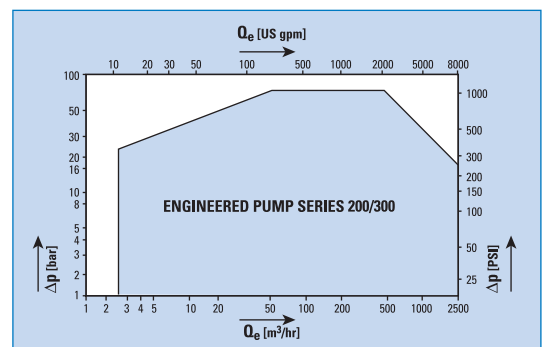

HOUTTUIN B.V.

Sophialaan 4, 3542 AR Utrecht
The Netherlands
P.O. Box 76, 3500 AB Utrecht
The Netherlands
Phone +31 - (0)30 - 2484611
Telefax +31 - (0)30 - 2411845
Telex 47280
Internet <http://www.houttuin.nl>